

Reinforced concrete double walls



HOW YOUR BUILDING WORKS TAKES PLACE FASTER WHILE YOUR COSTS REMAIN LOW

 **KERKSTOEL**
DOUBLE WALLS



Strength in building technology

The Kerkstoel reinforced double walls consist of two slabs of reinforced concrete joined to each other by open web girders. The wall elements are assembled on the site according to the plan then filled with concrete. The result is a solid construction and a strong base that is strong as a monolithic concrete wall. Kerkstoel double walls are manufactured in accordance with the strict standards of the Belgian conformity certificate and of ISO 9001.

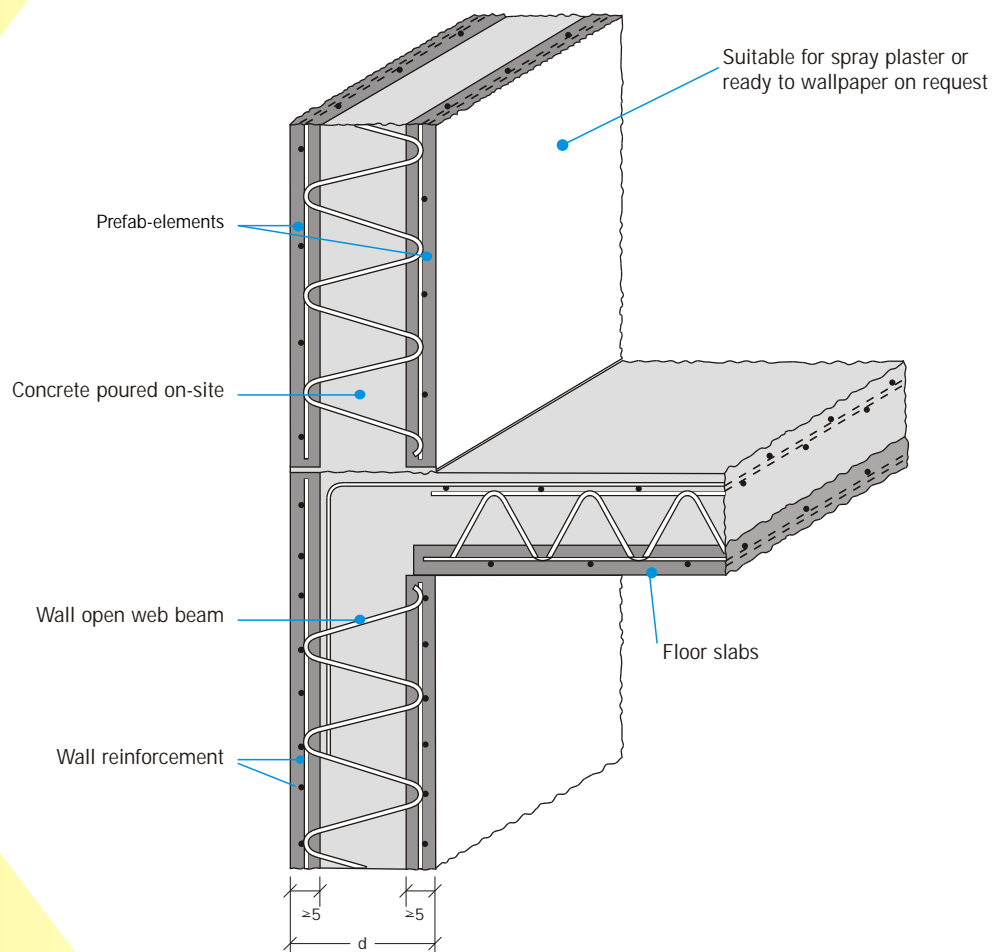

DIMENSIONS	length: up to 8.30 m
	height: up to 2.80 m, possibly up to 3.50 m on request
	thickness (outside/inside): 19-34 cm (on request 40 to 70 cm)
	thickness of the slabs: at least 5 cm each
	other dimensions on request
WEIGHT	approx. 250 kg per m ² with 2 x 5 cm slab thickness
CONCRETE QUALITY	at least C25-30
SURFACE	suitable for spray plaster or ready to wallpaper on request



Preparation of the floor slab

Make sure that the joining reinforcement is placed correctly with the concreting of the floor slab. Make sure that there is sufficient inside space.

Do not use mesh reinforcement as starter bars.

Trace the place where the walls must be erected with the numbers of the walls on the ground. The information can be found on the assembly plan.

Use base plates to accommodate unevenness of the floor.

If not otherwise arranged, make sure that the joint under the wall is 3 cm.

Four supports are to be levelled out for each element.
(under both surfaces ± 50 cm from both ends of the wall.)



Unloading of the walls supplied

VERTICAL

Sufficiently long hoisting cables must be used to guarantee an angle of at least 60° . Make sure that the element is always level. Use a pointer or hold with a chain block if necessary.

HORIZONTAL

In exceptional cases the walls are transported horizontally. Upon request we can also provide you with specially designed hoisting hooks with which one lifts the elements horizontally and stacks them horizontally next to the lorry. You must make sure that the ground surface is sufficiently stable and level for this. We advise placing a wooden beam between the hoisting hooks and the concrete elements to spread any concentrated loads. One can then pull the elements vertical with the transport anchors placed at the factory. We also advise the placing of a wooden beam between the hoisting hooks and the concrete elements here. Always make sure that the chains or cables are sufficiently long to guarantee an angle of 60° . The maximum weight per hoist anchor is 2 tons.

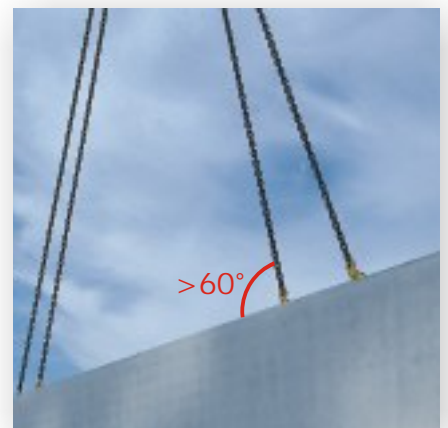



Placing the walls

Three people are needed for assembly. Make sure that with the bringing in of a new element the elements already in position are not displaced or damaged.

Gradually lower the element and push any protruding holding rods to the side. Place the element in line and up to the adjusting projections. Make sure that the joints are always perpendicular ± 2 cm. The position can still be corrected with a pry bar to afterwards set the positions with wedges.

Fix each element with two props on both sides. Screwed sleeves are provided in the walls. The holes needed in the floor slab still have to be drilled.

The crane hooks may only be removed after the elements have been fixed in place and checked.

Now apply the joint and corner reinforcement. Do not forget to form the recesses.



Correct concreting

Finish the joints as follows:

- . Horizontal joints must be propped up and formed if necessary.
- . Vertical joints must be formed if the joint is larger than 1 cm. For this you can make use of assembly foam.

Reinforce corners using angle bars or wooden planks. Props can be used for T-joints.

You can place the wide slab place before the walls are concreted. For this the walls must be assembled in a mortar bed or sufficiently wedged. The inner surface of the walls must be moistened before concreting.

Concreting must take place in accordance with the conditions provided. The infill concrete must be properly vibrated.

Important:

- . The permissible concrete pressure may not exceed 30 kN/m².
- . We advise you to vibrate for ± 60 % of the filling time.





Transport

Make sure that the crane and the deep-loaders have unimpeded access to the site. Here you must take account of possible street obstructions, the sharpness of bends, parked vehicles, etc.

The transport vehicles have a length of up to 18 m; the headroom amounts to at least 4 m.



VERTICAL TRANSPORT WITH CARRIAGE

This form of transport is used for walls taller than 2.80 m. The permissible ground unevenness is a maximum of 25 cm over a length of 6 m.

VERTICAL TRANSPORT WITH CONTAINER

Vertical transport with container is used for walls with a maximum height of up to 2.80 m.



HORIZONTAL TRANSPORT

With horizontal delivery the base surface of the lorries must be level.



Uses

Kerkstee double walls all have special advantages for different applications. Because each element is manufactured individually according to requirements, Kerkstee double walls are the ideal construction method for just about all building work. Below you can find some examples of the technical uses.

Private homes

Inside and outside walls, the replacement of brickwork, an alternative for concrete poured on-site



Tall walls

Tall walls can be produced at heights greater than 8 m for various uses.



Storey floors

Façade walls, dividing walls in homes, outside walls, lifts and stairwells, partition walls



Large construction projects

Industrial construction, silo walls, tunnels, underground car parks, supporting walls



Walls as waterproof constructions

Including basements, water treatment plants, retaining walls and swimming pools



Kerkstoel thinks of all the details

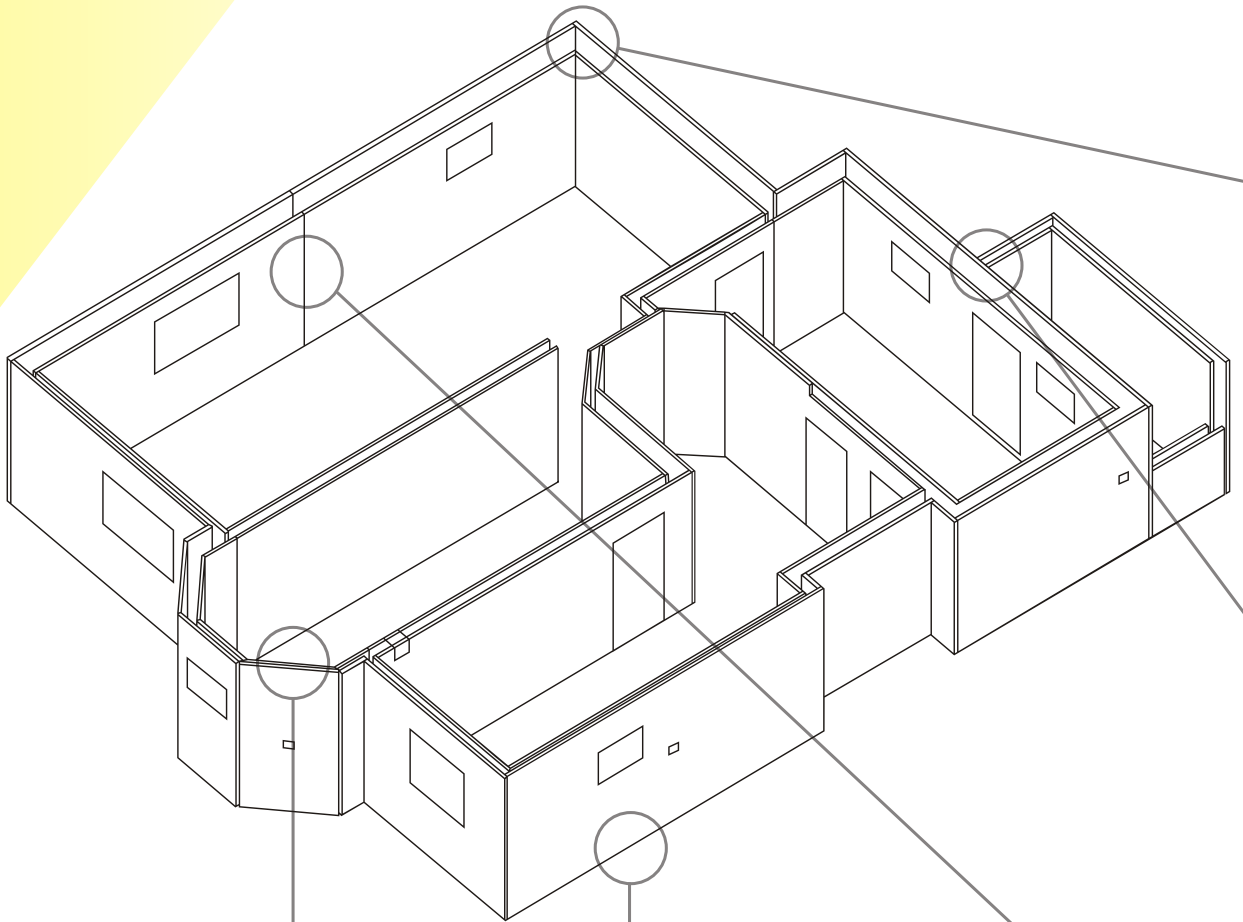

ceiling joints

base plate joints

(not reinforced)

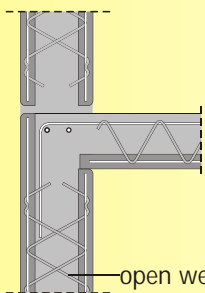

open web beam

(reinforced)

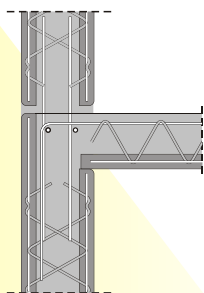

(not reinforced)

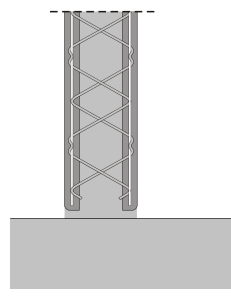

(reinforced)

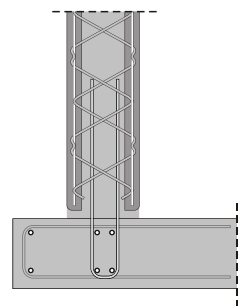



Building in groundwater

The bed plate is provided water-resistant concrete.

The outside walls can be of a maximum thickness and filled with water-resistant concrete.

Kerkstoel's high quality double wall elements and the concrete guarantee the complete watertightness of the wall. The joints are either sealed on the outside or given a sealing layer.

vertical joints

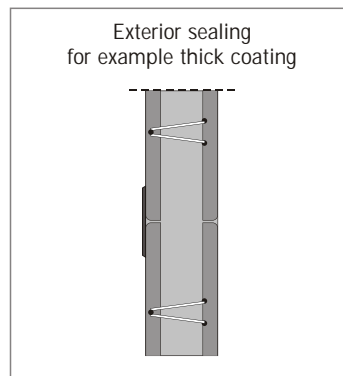
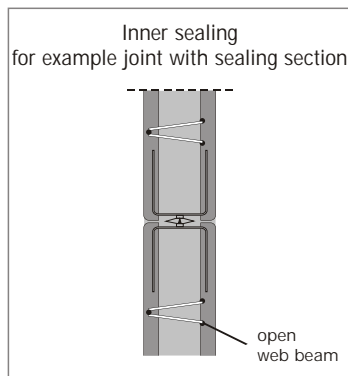

METHOD FOR GOOD WATER SEALING

horizontal joints

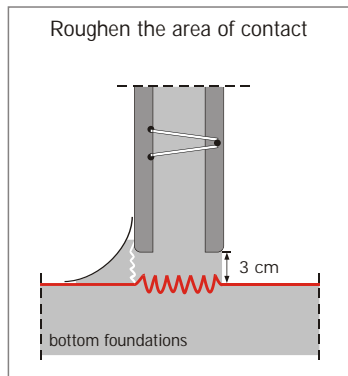

Roughen the area of contact. This limits the creeping of the concrete in relation to the foundations.

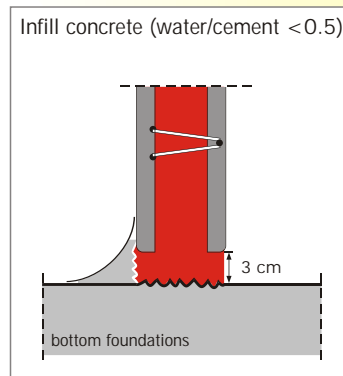

Always use suitable cement. The water/cement factor must always be less than 0.5.

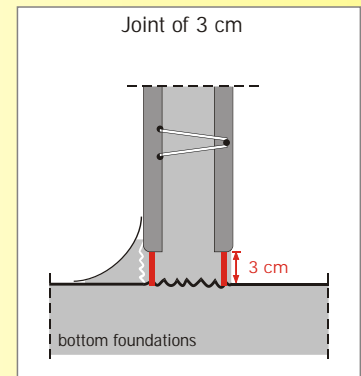

The wall must be placed ± 3 cm above the foundations. This means one can increase the contact area.

RESOURCES FOR WATER SEALING

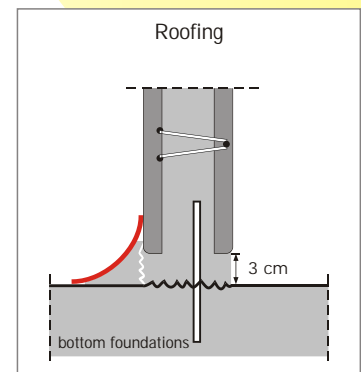
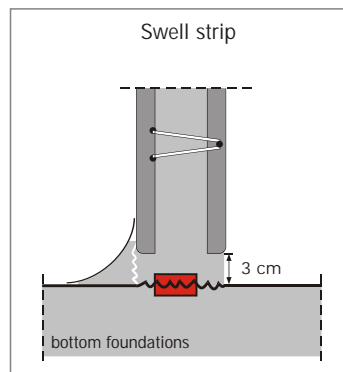
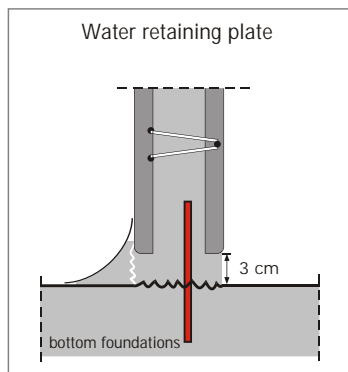



Completely watertight, also at the joints

Kerkstoel double walls are manufactured in optimal and precision-controlled conditions at the factory. Production faults are practically excluded by using an integrated quality management system. The double walls resist any water load and water pressure and any other form of moisture to which a building is exposed. Kerkstoel stands for reliability, and the certainty that all physical construction properties will be taken into account.

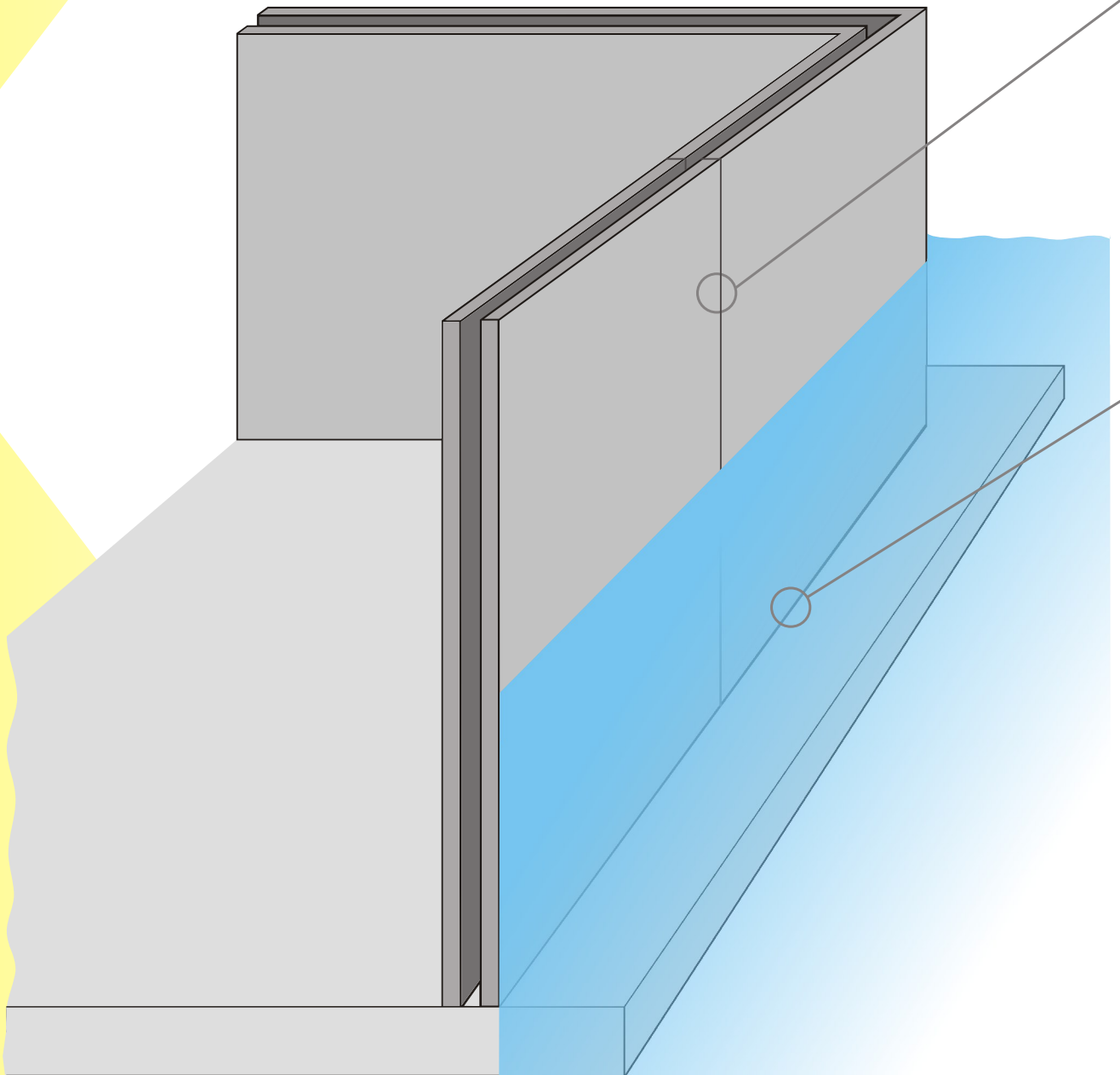



Kerkstoel offers technical support

We offer just-in-time logistical and qualified assembly assistance for the smooth completion of construction plans. We draw up a detailed assembly plan on the basis of the design of the architect (plan and cross-section), the stability calculations, formwork and installation plans. We develop the production plans and provide them with all the necessary details, so that everything goes smoothly and according to plan on the site.

DETAILS

for corners

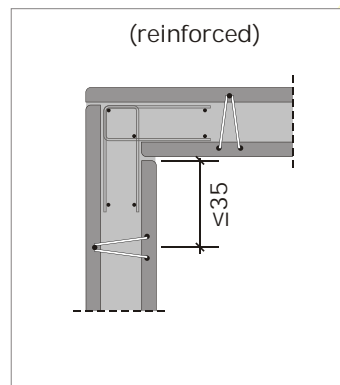
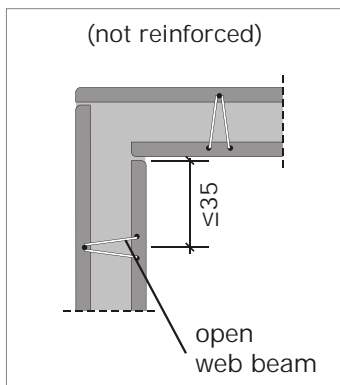

for wall joints

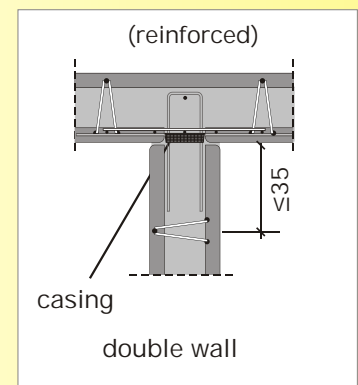
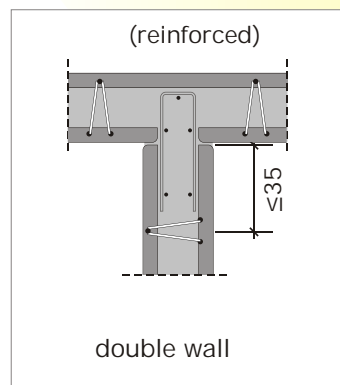
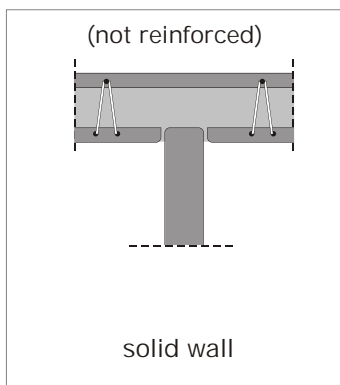

for vertical joints

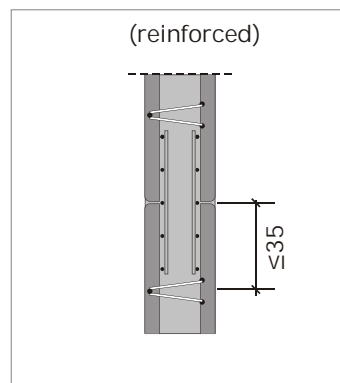
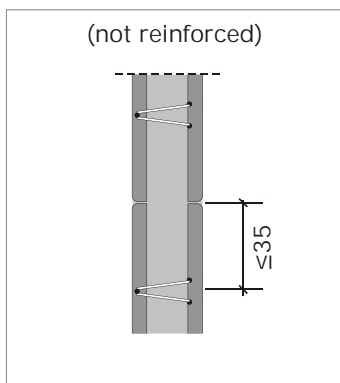



What else does Kerkstoel have to offer?

Because each architectural design has its own specific properties, Kerkstoel double walls are each time produced according to requirements. Not only does each wall have its own dimensions and openings for doors and windows, the built-in parts for the finishing can also be immediately provided. The use of the latest CAD and robot techniques allows Kerkstoel to produce double walls of even the most individual design at a very reasonable price.



Description of the built-in parts:

1. Door frames, wooden formwork
2. Windows or wooden formwork
3. Openings, passageways
4. Reinforcement for joints with concrete poured on-site
5. Electrical fittings
6. Pipes for the vertical powering of electrical installations.



Built-in parts for finishing

Window opening with formwork

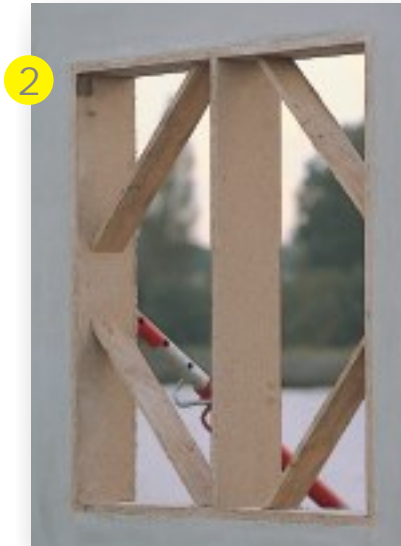

Doorway with formwork.
Any sizes are possible.

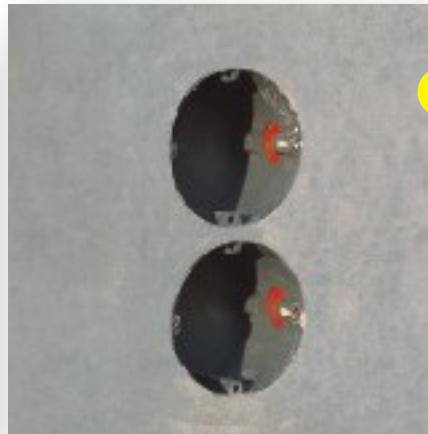

Provisions for electricity,
distribution and telephone

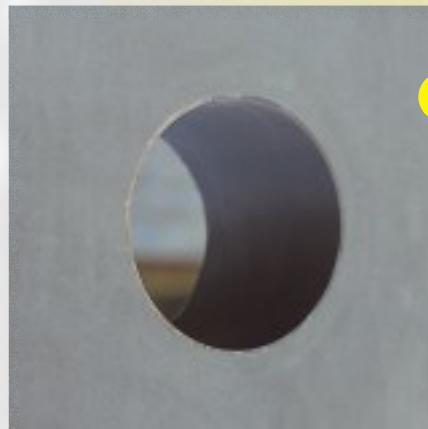

Openings for: incl. sewers,
air-conditioning, ventilation, etc.

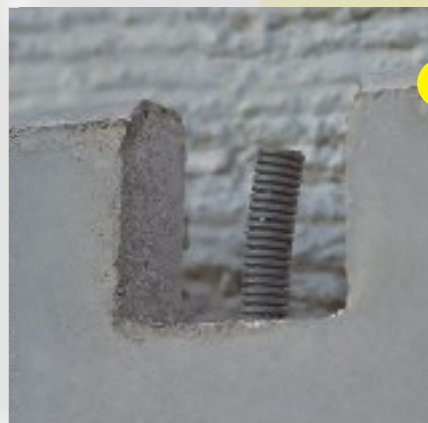

Pipes for the vertical powering
of the electrical installation, etc.



Faster, less expensive and perfect physical construction

MORE COST-EFFECTIVENESS

Because no formwork more is needed:

- . no rental, storage, investment costs/depreciations
- . no transport, expensive placing, removal or cleaning of the formwork
- . less dependent on personnel
- . ideal for single-sided formwork or gap construction: a possible take-over stipulation is not required
- . greater flexibility

COST-SAVING

- . insensitive to settling
- . less sealing material required
- . less transport and crane costs because of less weight
- . no mortar bed required for assembly
- . no joint problems because of the homogenous nature of the concrete deposited on-site
- . simple connecting of base plate and ceiling with the joint reinforcement in the infill concrete

SHORTER CONSTRUCTION TIME

- . lower financing costs
- . production at the factory independent of weather conditions
- . no waiting times for the removal of formwork
- . no edge trestle required as support for the wide slabs
- . in-built elements such as windows, doors, door frames, cable ducts and electrical boxes can already be built in at the factory
- . particularly smooth surface areas on the inside and outside: suitable for spray plaster
- . delivered ready to wallpaper on request: no traditional plastering necessary
- . just-in-time delivery

EXTRA BENEFITS

- . individual production, geared to each project
- . good acoustic insulation
- . just about no limitations as regards static possibilities
- . combination of the advantages of concrete poured on-site and prefab-elements
- . edge formwork for wide slabs already provided in the wall elements



FOTO'S STEF DAANS

Kerkstoel 2000+ satisfies the highest quality standards.



KERKSTOEL 2000+ N.V.

Industrieweg 11

B-2280 Grobbendonk

Tel. +32 (0)14 50 00 31

Fax +32 (0)14 50 22 48

<http://www.kerkstoel.be>

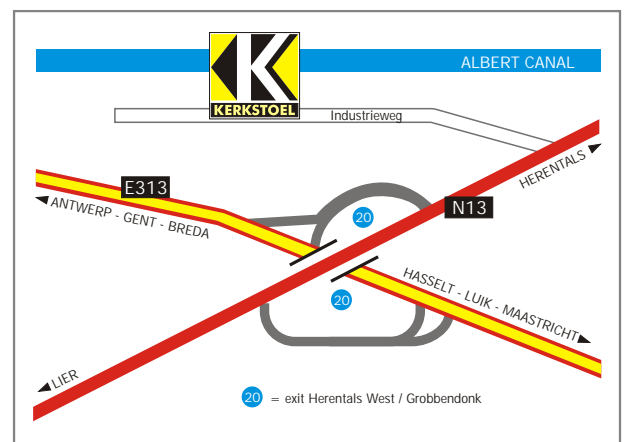

These assembly instructions are intended as advice. The information is based on current standards and technical approval and our many years of experience. They are however not binding. Our assembly supervisors under no circumstances accept the role and the liability of the authorised supervisor. This also applies for any employees of our company and our suppliers on the building site. Variations in colour and surface with respect to the prospectus material as well as technical and static changes reserved.